

# Research Progress of Backfill Materials for Borehole Heat Exchangers: from Performance Optimization to Solid Waste Utilization

Yudi Wang

School of Mines, Guizhou University, Guiyang 550025, China

Peng pei\*

School of Mines, Guizhou University, Guiyang 550025, China



## Research Background

Backfill material is the heat exchange medium between the U-pipes and the surrounding ground in ground-coupled heat pumps (GCHP), and its properties determines the system efficiency.

RESEARCH OBJECTIVE: through reviewing challenges for high performance backfill materials, and research progress of state-of-art technologies :

- targeted suggestions are proposed for improving material properties;
- identify future trend for multi-function backfill materials, including material modification, waste reduction, and groundwater pollution control.

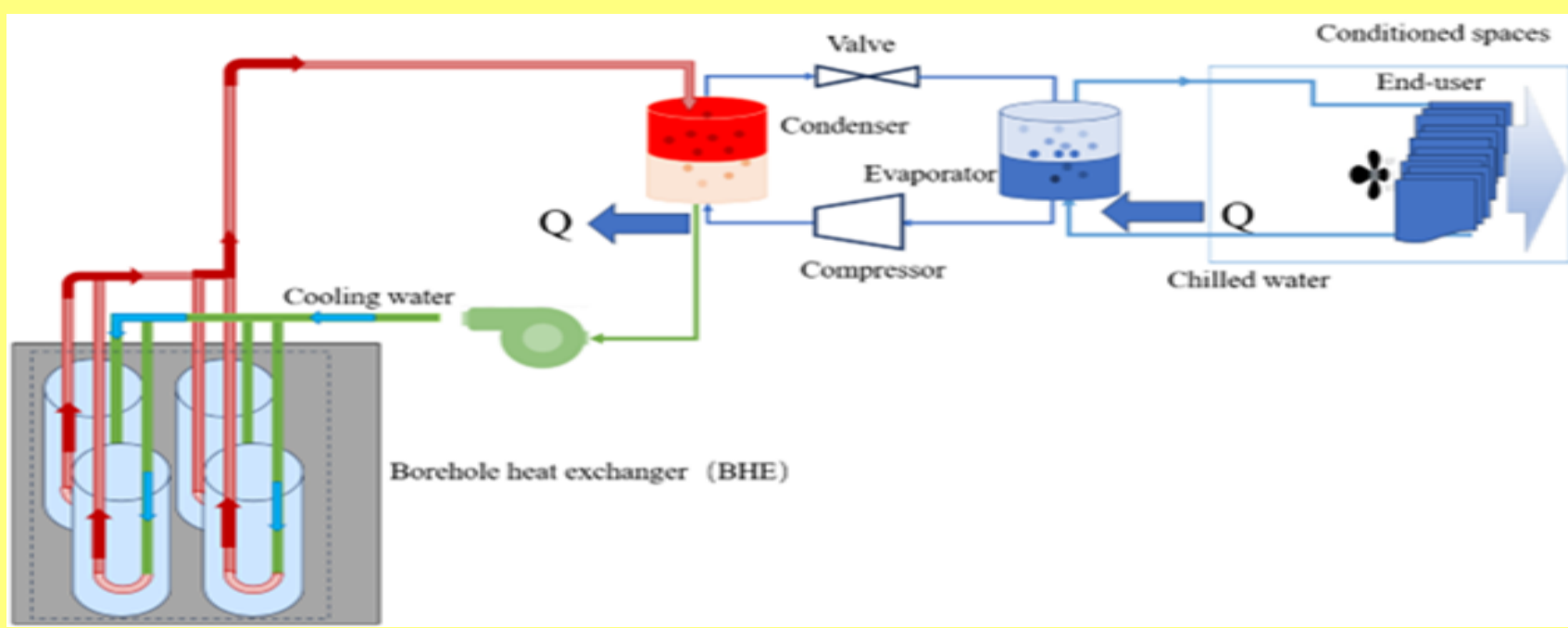

Fig.1 Ground-coupled heat pump system (taking the cooling mode as an example)

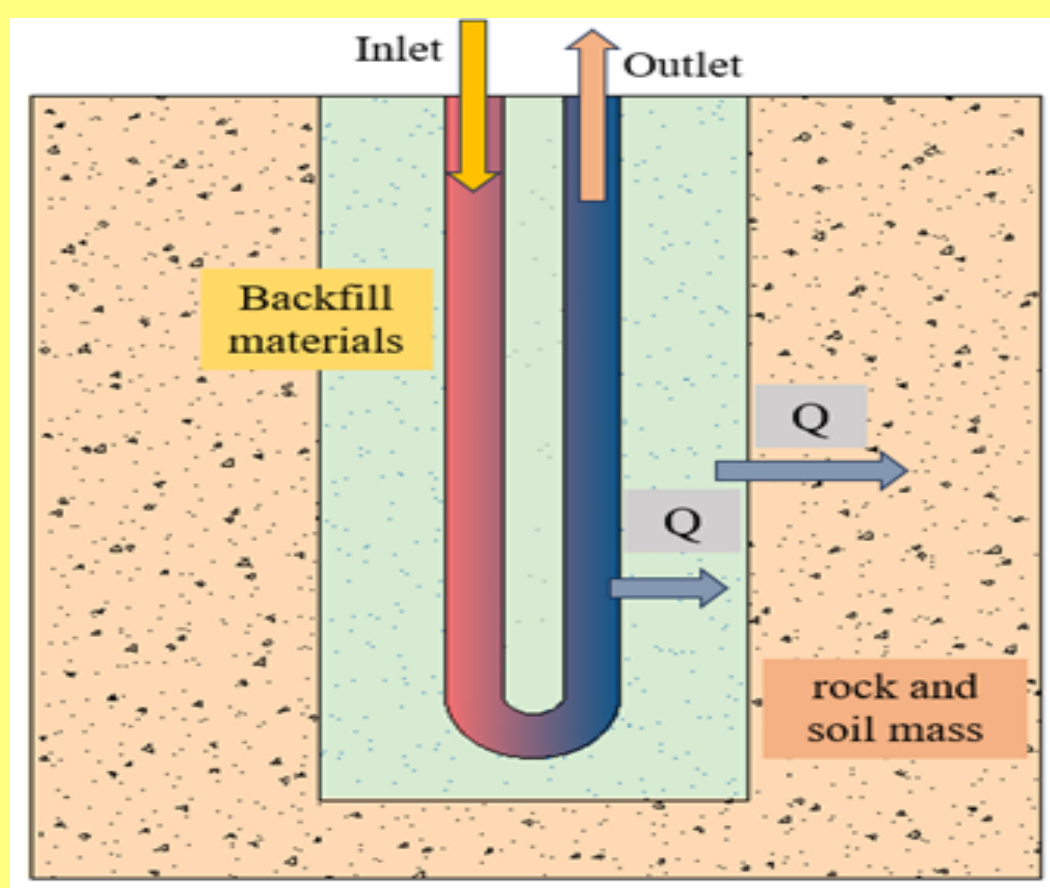

Fig.2 Heat transfer among U-pipe, backfill materials and surrounding ground

## Technology Roadmap

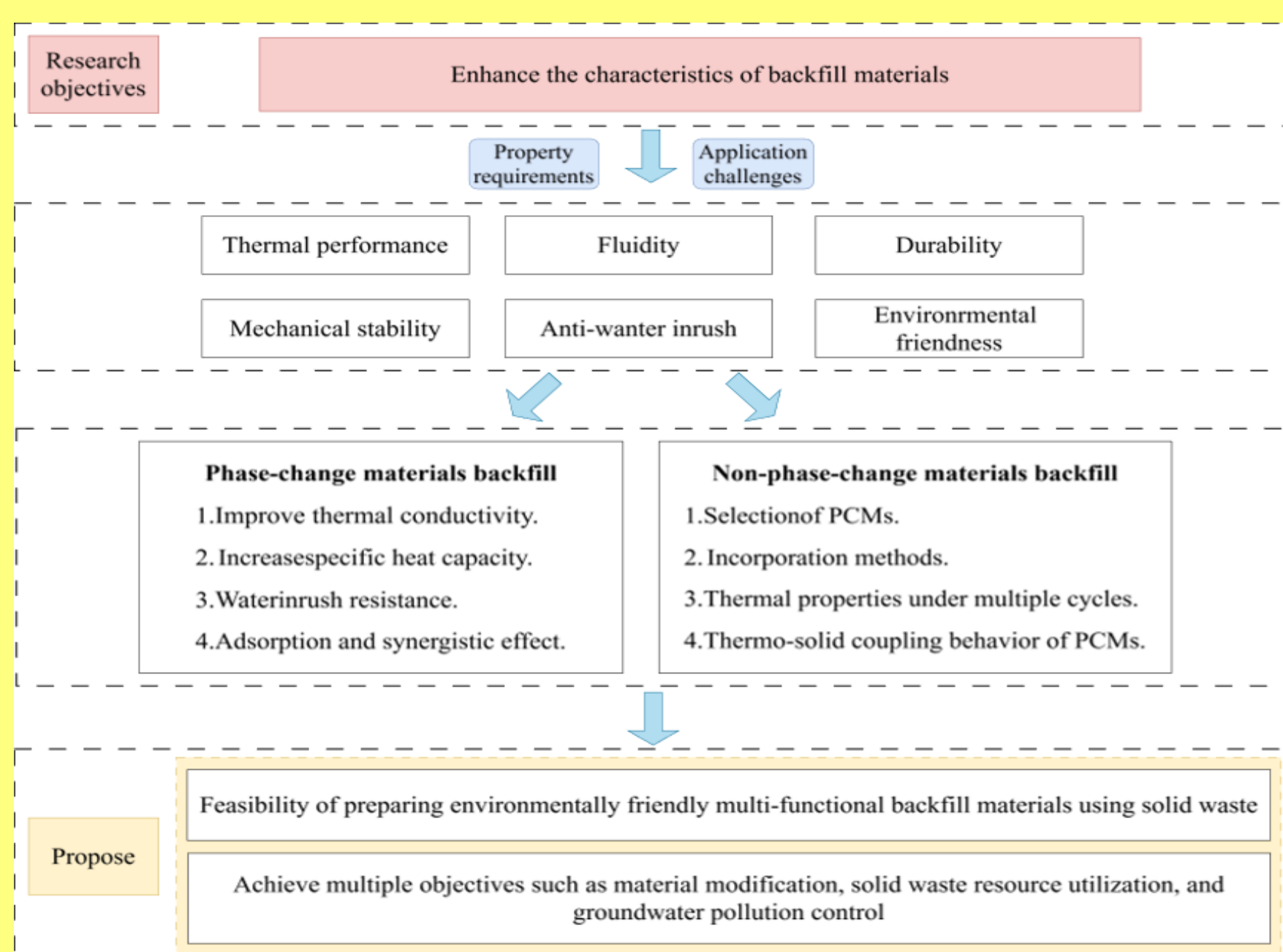

Fig.3 Technology roadmap

## Research Content

Essential Requirement for Backfill Materials: Moderate and High Thermal Conductivity, Relatively High Specific Heat Capacity, Compactness and Impermeability, Long-Term Mechanical Stability, Environmental Friendliness, Easy Construction and Low Cost.

### MAIN CHALLENGES

- Balance among Thermal Conductivity, Specific Heat Capacity, and Thermal Diffusivity.
- Coupling Mechanism and Threshold Effects of Additives on Mechanics/Impermeability/Thermal Properties.
- Phase Change Material Encapsulation/Leakage and Cyclic Stability.
- Water Inrush and Pollution Risks in Groundwater-rich environment

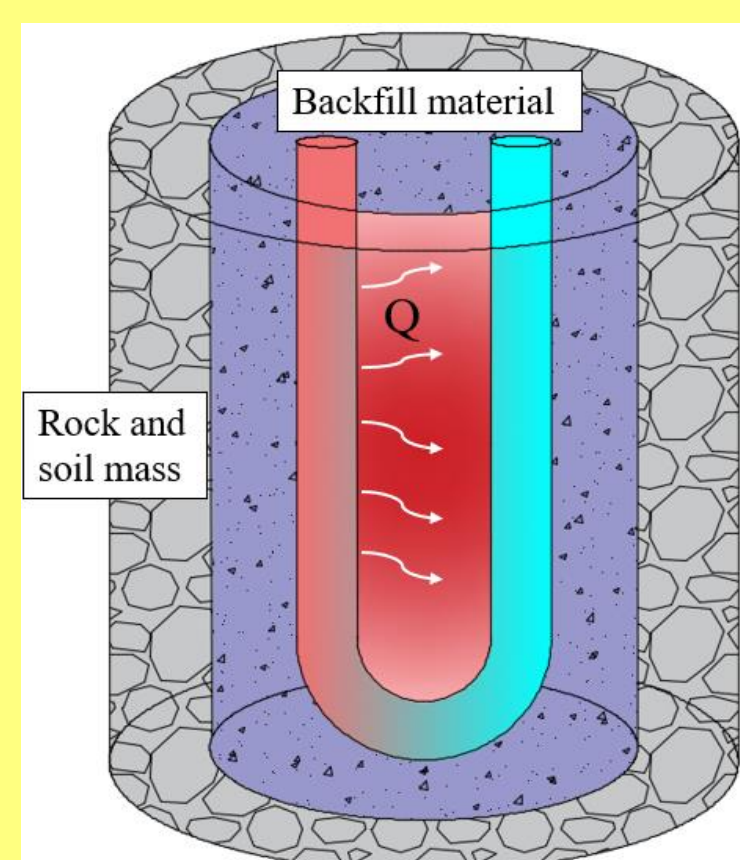

Fig.4 Three types of seasonal BTES numerical simulations

Common backfill materials: borehole cuttings, sand, cement-based materials, bentonite.

### 1.THERMAL CONDUCTIVITY ENHANCEMENT

- Metal powders (iron powder, aluminum) materials can significantly improve thermal conductivity.
- Non-metallic additives (barite, granite powder, kaolin) slightly improve thermal conductivity while maintaining good compatibility.

Table 1 Typical additives used to improve the thermal conductivity of borehole backfill materials

	Thermal conductivity performance
Iron powder	Maximum increase of 50%
Aluminum	The thermal conductivity is improved by 170%.
graphite	The thermal conductivity increases by 20%~60%.
kaolin	The thermal conductivity increases from 1.81 W/(m·K) to 2.81 W/(m·K)
barite powder	The thermal conductivity increases by approximately 12%.
granite	The thermal conductivity is improved.

Table 2 Common high thermal conductivity additives for backfill materials

Categories	Typical Materials	Thermal Conductivity Range, W/(m·k)
Metallic Materials	Cu	386
	Al	237
	Zn	212
	Fe	80
Carbon based Materials	Graphene	2000-5200
	Carbon Fiber	300-1000
	Graphite	100-400
	Single-walled Carbon Nanotubes (SWCNTs)	3500 [57]
	ZNO	20-60
Non-metallic Materials	SiC	120
	SiO <sub>2</sub>	1-10
	BeO	270
	BN	30-330

### 2. HEAT CAPACITY ENHANCEMENT

Increase moisture content, Use molecular sieves, Add coal-based solid waste.

### 3. PREVENT WATER INRUSH IN BOREHOLES AND HYDRAULIC CONNECTION WITH AQUIFERS

(1).Water inrush in boreholes:

- Cement-based backfill materials tend to form fracture networks under the effects of temperature gradient, drying shrinkage, internal stress, freeze-thaw cycles, liquefaction of phase change materials.
- The formation of fracture networks changes the flow paths of groundwater

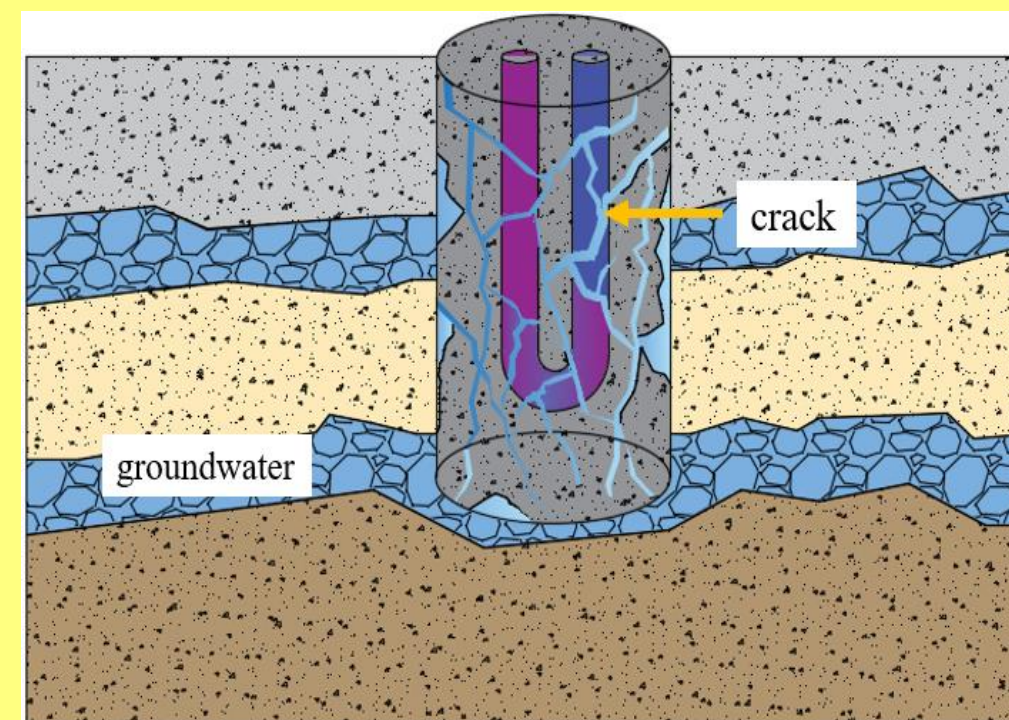

Fig. 5 Connection between different aquifers due to cracking in boreholes

(2).Countermeasures:

- Optimize material ratio and add water-proof layer materials.
- Reduce the addition ratio of phase change materials (PCM) .
- Adopt intermittent operation mode.

### 4. ADSORPTION AND SYNERGISTIC EFFECT

Expanded Graphite (EG) has excellent properties such as high thermal conductivity, corrosion resistance and high temperature resistance. Also, its loose porous structure endows it with large specific surface area and strong adsorption capacity can be used to reduce pollutant in BHE construction pollutants such as engine oil.

When EG is mixed into the backfills at a certain proportion, its oil adsorption rate can reach 70-80%.



Fig.7 Flow chart of the adsorption experiment of engine oil by EG

Table 3 Experimental data of engine oil adsorption by EG

Volume ratio of EG	Initial mass of graphite /g	Mass of graphite in Group 1 (10 g engine oil) /g	Adsorption capacity /g	Oil reduction rate /%	Mass of graphite in Group 2 (20 g engine oil) /g	Adsorption capacity /g	Oil reduction rate /%
10%	10.0	14.6	4.6	46.0	17.8	7.8	39.0
30%	30.0	38.1	8.1	81.0	44.7	14.7	73.5

### 5.PCM AS AN ADDITIVE FOR BACKFILL MATERIALS

Advantages of phase change materials: high latent heat of phase change, load shifting, and reduction of thermal influence radius.

(1).Main problems: low thermal conductivity, liquid leakage, mechanical softening and poor cyclic stability.

(2).Common forms : Microencapsulated phase change material (MEPCM), Adsorption/form-stable composites (EG adsorption, skeleton adsorption), Direct blending.



Fig. 9 Phase Change Microcapsule (MEPCM) Material

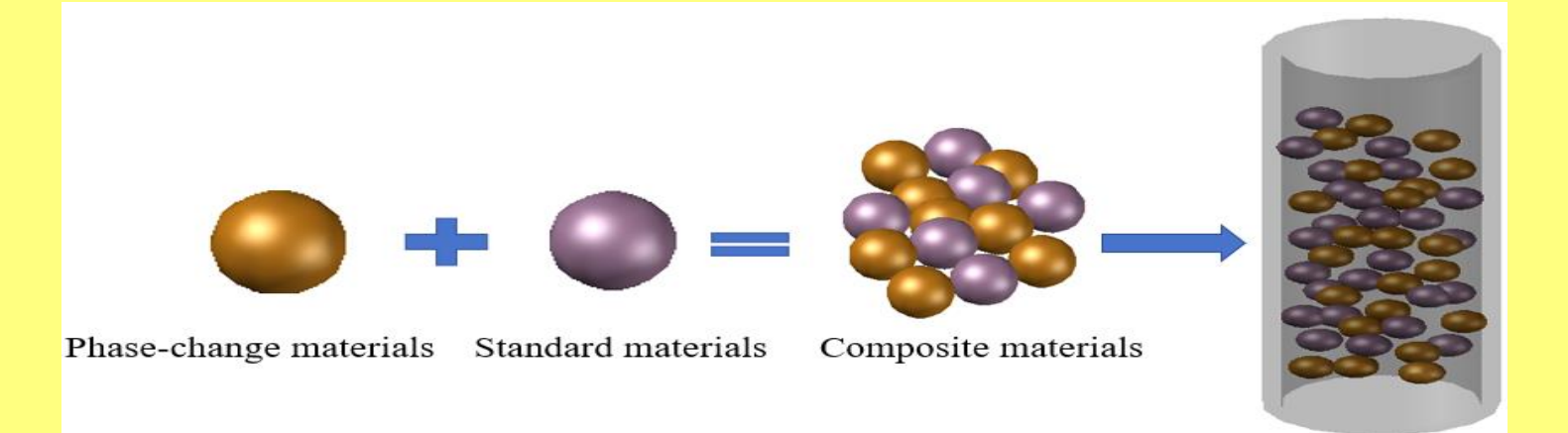

Fig.10 Direct Blend Type (PCBM)Material

Design Recommendations: Prioritize the selection of organic solid-liquid PCMs (with low supercooling and chemical stability) and composite them with high-thermal-conductivity carriers.

### 6. MULTI-CYCLE THERMAL PERFORMANCE AND THERMO-SOLID COUPLING OF PHASE CHANGE MATERIALS

- Low-conductivity PCMs easily accumulate heat under cyclic operation and reduce heat transfer efficiency.
- A low start-stop ratio promotes PCM solidification and heat capacity recovery.
- PCM repeated liquid-solid phase change induces local stress and mechanical property fluctuations.

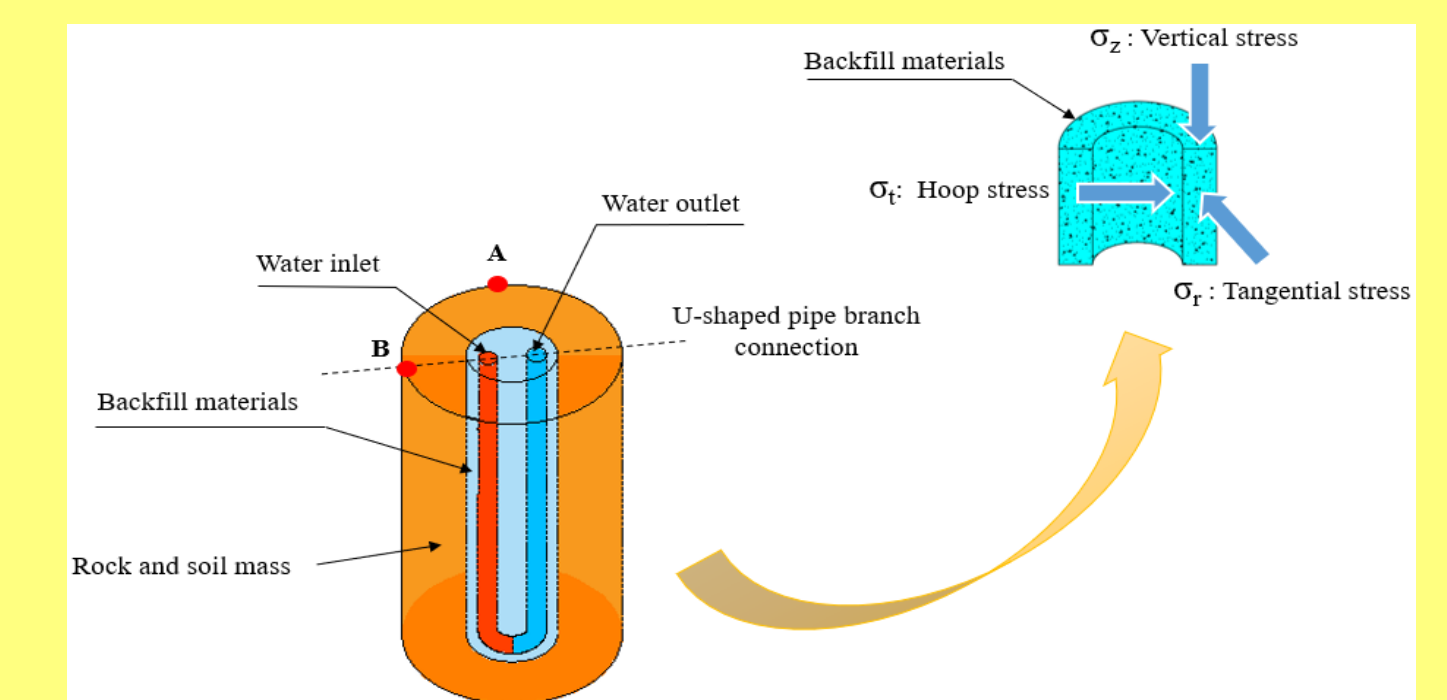

Fig. 11 Stress analysis in PCBM borehole

Conclusion: High-thermal-conductivity PCMs combined with an intermittent operation strategy are essential for achieving sufficient solidification and performance recovery.

## Results and Discussion

### 1.SUGGESTIONS FOR IMPROVEMENT IN PROPERTIES

- Thermal conductivity modification effect: Graphite, expanded graphite and metal powder greatly enhance thermal conductivity; but there is a risk of settlement and stratification.
- Specific heat and energy storage: Molecular sieves, PCMs and solid waste-based thermal storage materials can enhance heat capacity, while PCMs require high-thermal-conductivity carriers and appropriate operation strategies.
- Mechanical properties and durability: Excess PCM/microcapsule incorporation degrades structural strength, while solid waste geopolymerization improves mechanical properties and stabilizes pollutants simultaneously.
- Water inrush resistance and environmental safety: Composite water-resisting layers combined with EG adsorption can effectively reduce water inrush risks and the diffusion of oil pollutants.

### 2. AVAILABLE SOLID WASTE TYPES

Wastes such as waste sand, crushed stone, broken bricks, recycled concrete, as well as by-products of metal smelting (e.g., copper slag, aluminum slag, iron filings, iron ore fines and iron tailings, Blast furnace slag).

Table 4 Thermal conductivity of typical solid waste materials

Solid waste materials	Thermal conductivity (W·m <sup>-1</sup> ·K <sup>-1</sup> )
Natural steel slag	0.75
Aluminum slag	17.34
Copper slag	0.78
Steel rolling scale	0.42
Crushed concrete	1.28
Crushed brick (Type W)	0.65
Crushed brick (Type R)	0.62
Coarsely crushed basalt	1.24
Fine basalt	2.04
Iron ore pellets / Iron filings	0.55-0.60
Fly ash	0.28

(1) Advantages

- Low cost, abundant resources, and capable of improving thermal conductivity and mechanical properties (some wastes possess favorable thermal conduction and chemical activity).
- A stable matrix can be formed via alkali-activated geopolymer or cementitious system to achieve pollutant immobilization.

2. Key challenges and modification approaches:

- Control of heavy metal leaching (solidification/stabilization).
- Balance the mechanical properties and thermophysical properties of materials.(the incorporation of high-thermal-conductivity additives)
- How to weight the importance among mechanical properties, heat transfer characteristics, heavy metal leaching behavior and adsorbability.